

SECTION A-A
HOW TO MATE AND UNMATE

MATE:	①	→	⑤
UNMATE:	⑥	→	⑨

- NOTES:
- MATERIAL:
 - HOUSING: THERMOPLASTIC, HIGH TEMP., UL94V-0; COLOR:BLACK.
 - CONTACT: COPPER ALLOY
 - FINISH:
 - CONTACT:
 - 50~100u" NICKEL UNDERPLATING OVERALL.
 - GOLD FLASH ON CONTACT AND MATTE TIN ON SOLDER
 - FITTING NAIL:
 - 50~100u" NICKEL UNDERPLATING OVERALL.
 - GOLD FLASH PLATING
 - REFLOW SOLDER CAPABLE TO 260°C PER ACES SPEC.
 - SPEC. PLS. REFER TO PS-53014-XXXX-XXX
 - PACKAGE PLS. REFER TO 53011-002XX-05-TRP
 - BATTERY:CR2032
 - PART NUMBER

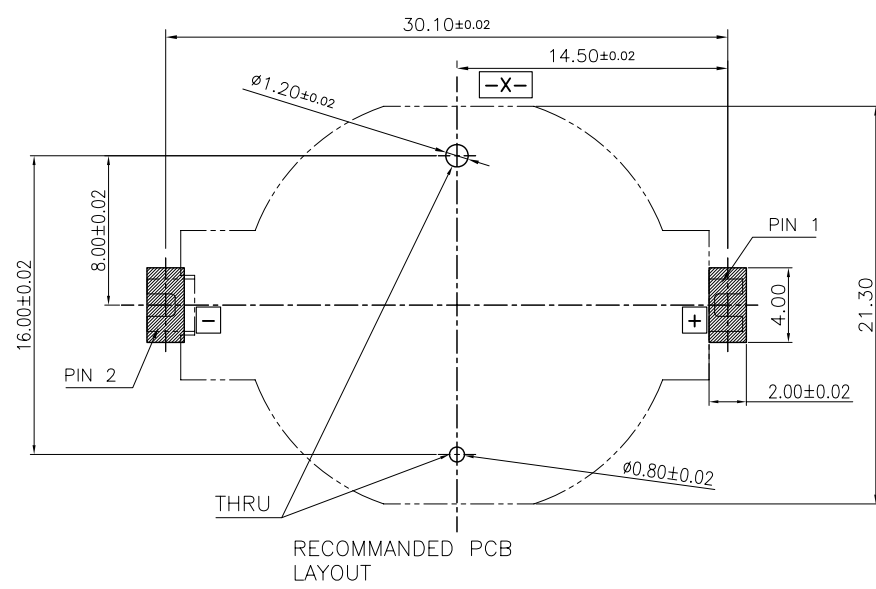
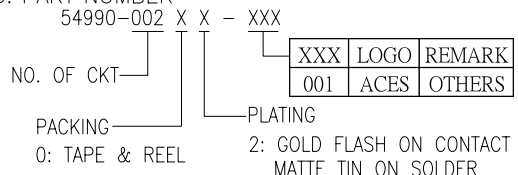

QUALITY SYMBOLS MAJOR CRITICAL GENERAL TOLERANCES (UNLESS SPECIFIED) X ±0.50 .X ±0.25 .XX ±0.15 .XXX ±0.10 ANGLES ±2°	DRAWN BY Lei, shanjun DATE '17/11/22	 BATTERY HOLDER CONN. 4.6H SMT TYPE
	CHECKED BY Lu Jing Quan DATE '17/11/22	
	APPROVED BY hsieh fu yu DATE '17/11/22	DWG NO. 54990-002xx-xxx
	UNITS mm SCALE 2:1	 SHEET NO. 1 OF 1